

Technical Information

TP28M10/2 D



AQUAFIX BELGIUM BVBA
Tel. 013 66 83 03, WWW.AQUAFIX.BE



AQUAFIX MILIEU B.V.
Tel. 0297 26 29 29, WWW.AQUAFIX.NL

Operating data	
Flow	0 m ³ /h
Head	0 m
Shaft power P2	
Pump efficiency	s %
Required pump NPSH	
Pumpe type	Single head pump
No. of pumps	1
Fluid	Water, clean

Pump	
Pump Code	TP28M10/2 D
Impeller	Single vane impeller
Impeller size	107 mm
Solid size	28 mm
Discharge port	R 1 1/2" IG
Suction port	s

Motor	
Rated voltage	400 V
Frequency	50 Hz
Rated power P2	0.7 kW
Rated speed	2900 rpm
Number of poles	2
Efficiency	70 %
Rated current	1.8 A
Degree of protection	IP 68

Materials	
Motor housing	Grey cast iron GG25
Impeller	Grey cast iron GG25
Pump housing	Grey cast iron GG25
Motor shaft	Stainless steel 1.4104
Bolts	Stainless steel
O-Rings	Nitrile Rubber
Lip seal on motor side Nitrile Rubber	
Mechanical seal on medium side SiC / SiC	
Lower Bearing Single row angular contact ball bearing	
Upper Bearing Deep Groove Ball Bearing	

Testnorm: ISO9906 Sect. 4.4.2

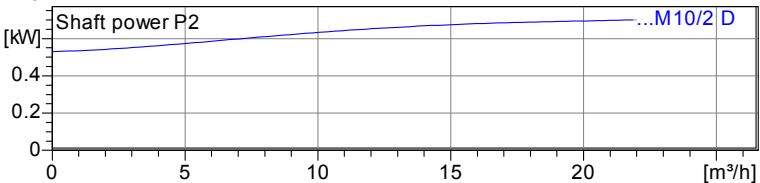
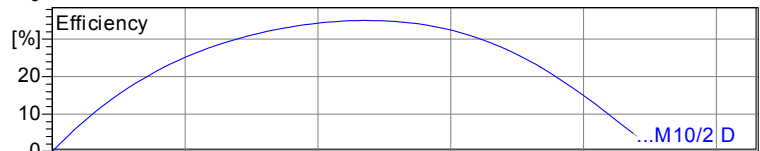
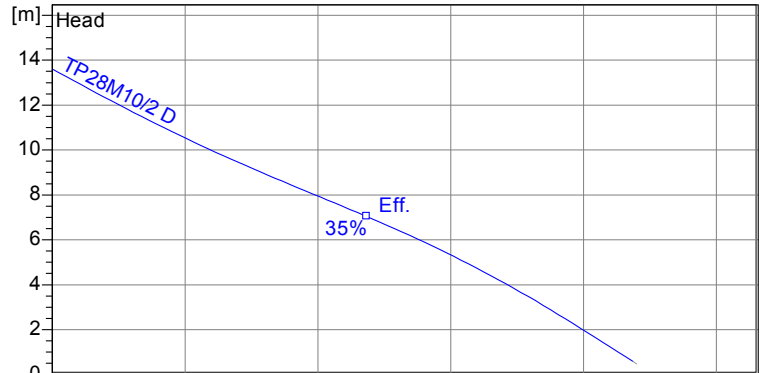

Wet well installation with coupling kit
Dimensions in mm,

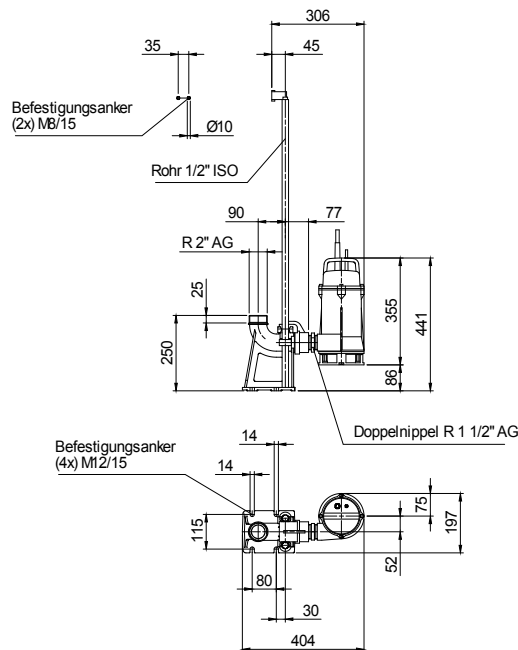

Table Dimensions (mm)

2.3.7 - 14/03/2012 (Build 345)

Project	Project no.:	Created by:	Page: 1
---------	--------------	-------------	------------

Performance Curve

TP28M10/2 D



AQUAFIX BELGIUM BVBA
Tel. 013 66 83 03, WWW.AQUAFIX.BE



AQUAFIX MILIEU B.V.
Tel. 0297 26 29 29, WWW.AQUAFIX.NL

Impeller						
Impeller type: Single vane impeller	Solid size 28 mm	Ø:	Max. Ø: 107 mm	Min. Ø: 107 mm	Sel. Ø: 107 mm	

Operating data					
Speed: 2900 rpm	Frequency: 50 Hz	Duty point: Q = 0 m³/h	H = 0 m	Shaft power P2:	Discharge port: R 1 ½" IG

Power data referred to:
Water, clean [100%] ; 20°C; 998.3kg/m³; 1.005mm²/s

Testnorm: ISO9906 Sect. 4.4.2

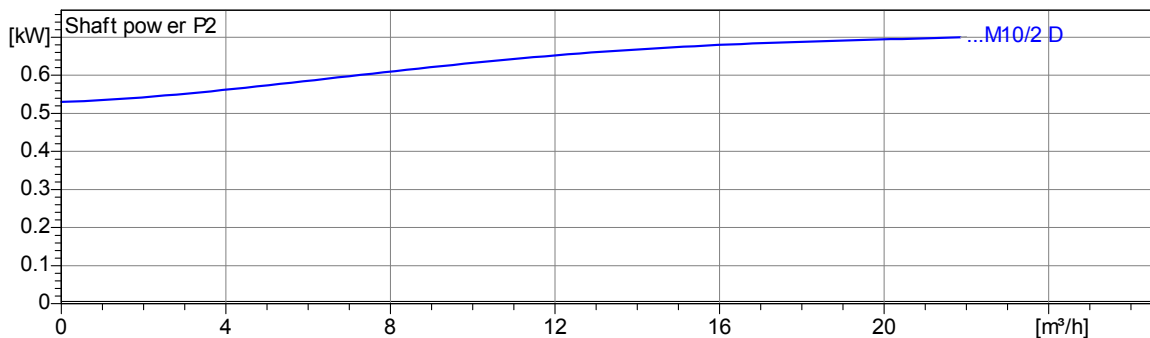
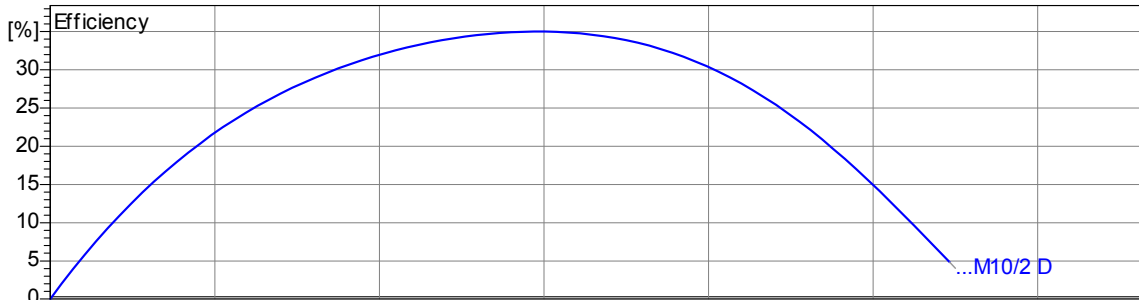

2.3.7 - 14/03/2012 (Build 345)

Project	Project no.:	Created by:	Page: 2
---------	--------------	-------------	------------

Dimensions

TP28M10/2 D



AQUAFIX BELGIUM BVBA
Tel. 013 66 83 03, WWW.AQUAFIX.BE



AQUAFIX MILIEU B.V.
Tel. 0297 26 29 29, WWW.AQUAFIX.NL

Wet well installation with coupling kit
Dimensions in mm, le

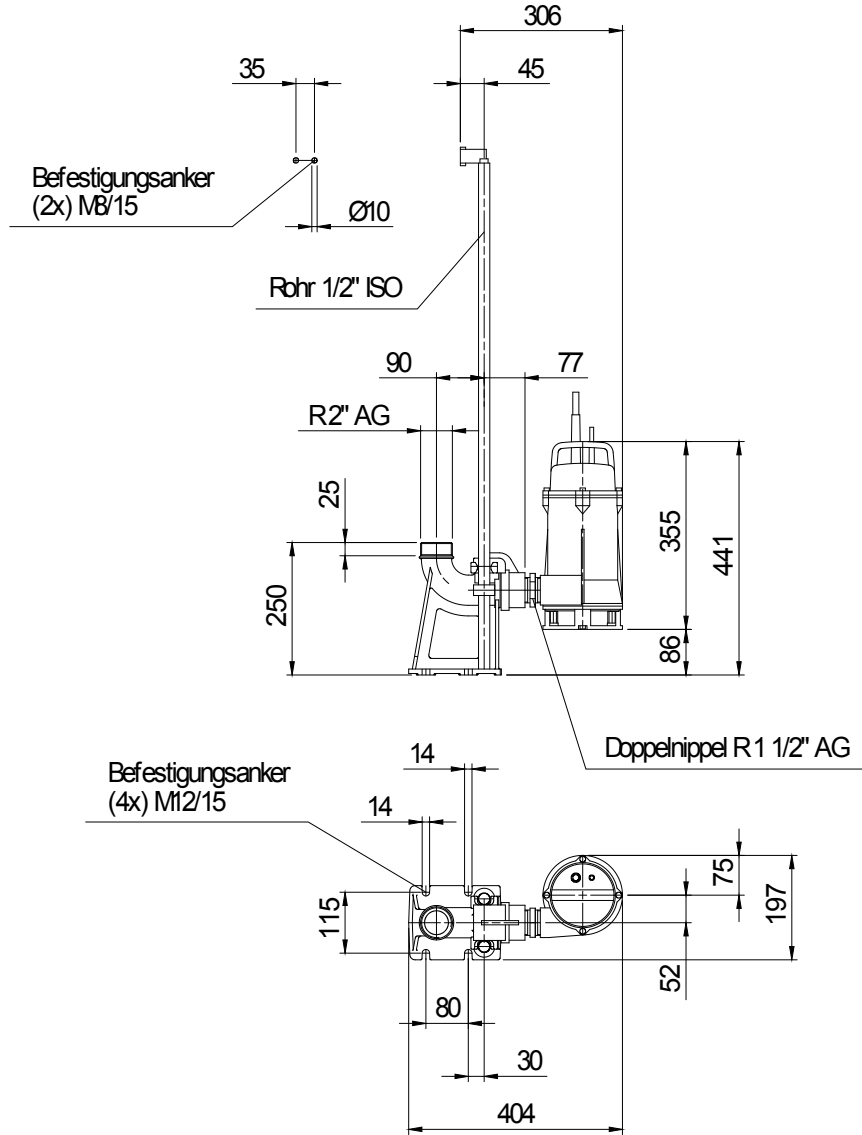

Table Dimensions (mm)

--	--	--

2.3.7 - 14/03/2012 (Build 345)

Project	Project no.:	Created by:	Page: 3
---------	--------------	-------------	------------

Technical Data

TP28M10/2 D



AQUAFIX BELGIUM BVBA
Tel. 013 66 83 03, WWW.AQUAFIX.BE



AQUAFIX MILIEU B.V.
Tel. 0297 26 29 29, WWW.AQUAFIX.NL

Operating data					
Flow	0 m ³ /h	m ³ /h	Head	0	m
Shaft power P2		kW	Geodetic head	0	m
Pump efficiency	s	%	Required pump NPSH		m
Pumpe type	Single head pump		No. of pumps	1	
Fluid	Water, clean		Temperature	20 °C	
Density	998.3	kg/m ³	Kin. viscosity	1.005	mm ² /s

Pump					
Pump Code	TP28M10/2 D		Speed	2900	rpm
Suction port			Head	Max.	13.6 m
Discharge port	R 1 1/2" IG			Min.	0.6 m
Impeller type	Single vane impeller		Flow	Max.	21.9 m ³ /h
Solid size	28	mm	Pump efficiency max.	35 %	
Impeller Ø	107	mm	Required rated power max. P2	0.7	kW

Motor					
Motor version	Submersible motor		Insulation class	H	
Motor name	AM 1,0/2 D		Degree of protection	IP 68	
Frequency	50	Hz	Temperature class		
Rated power P1	1.0	kW			
Rated power P2	0.7	kW	Explosion protection		
Rated speed	2900	rpm	Efficiency	100%	70 %
Rated voltage	400	V 3~	at % rated power	75%	%
Rated current	1.8	A		50%	%
Starting current, direct starting	10.8	A	cos phi	100%	0.80
Starting current, star-delta	3.	A	at % rated power	75%	
Starting mode	Directly			50%	
Power cable	4G1,5		Control cable		
Type of power cable	H07RN-F		Type of control cable		
Cable length			Service factor	1.15	
Shaft seal	Lip seal on motor side		Nitrile Rubber		
	Mechanical seal on medium side		SiC / SiC		
Bearing	Lower Bearing		Single row angular contact ball bearing		
	Upper Bearing		Deep Groove Ball Bearing		
Remarks	s				

Materials / Weight			
Motor housing	Grey cast iron GG25	O-Rings	Nitrile Rubber
Pump housing	Grey cast iron GG25		
Impeller	Grey cast iron GG25		
Motor shaft	Stainless steel 1.4104		
Bolts	Stainless steel		
Weight aggregat	22 kg		

Project	Project no.:	Created by:	Page: 4
---------	--------------	-------------	------------

2.3.7 - 14/03/2012 (Build 345)