

ATK-S Ø110

Top view close

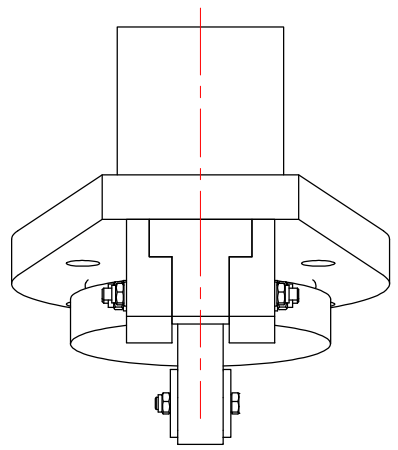

Y: 381mm

X: 250mm

Z: 276mm

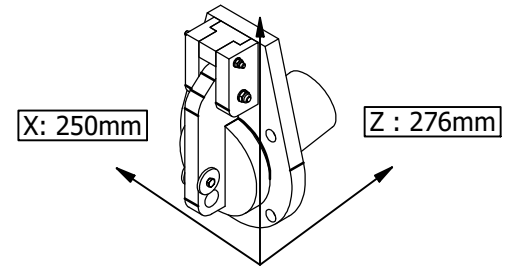

Front view close

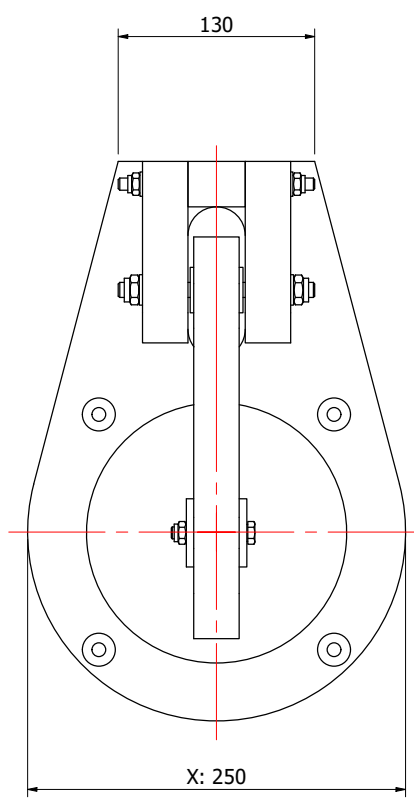

Side view close

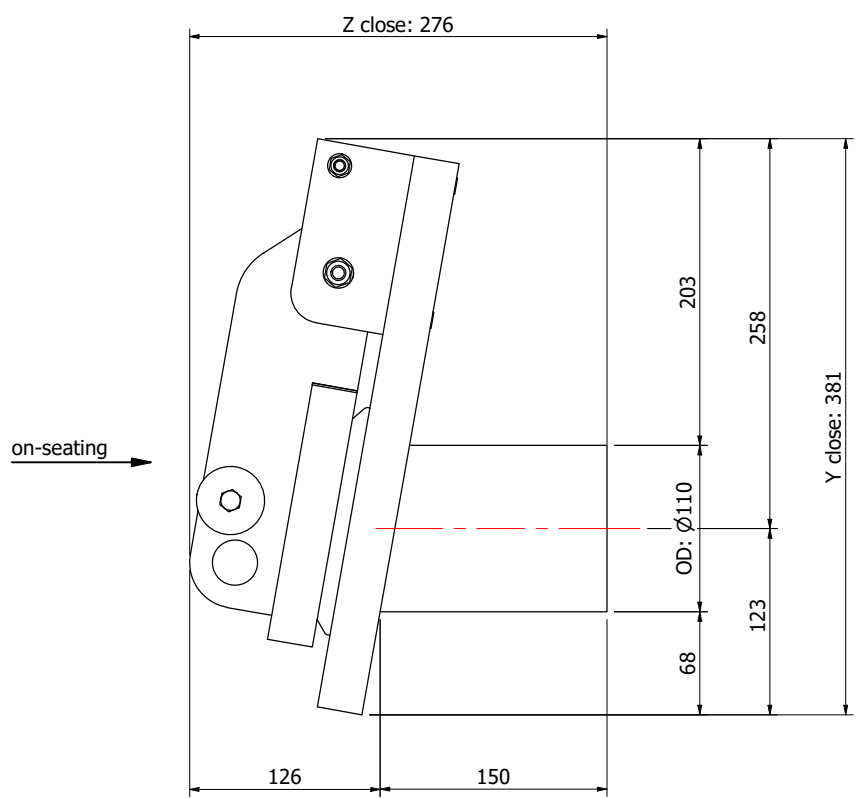

Side view open

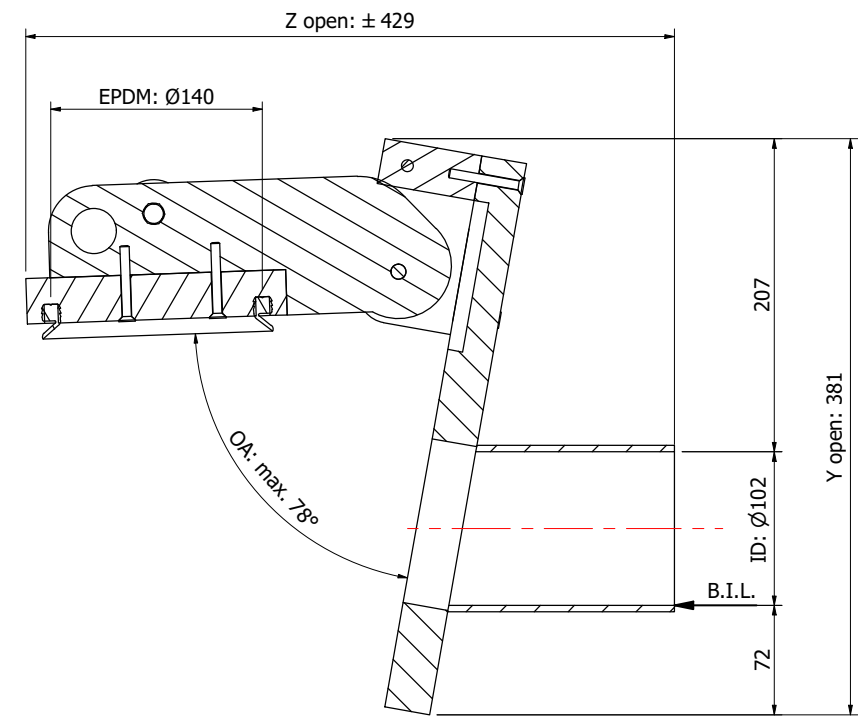

Back view close

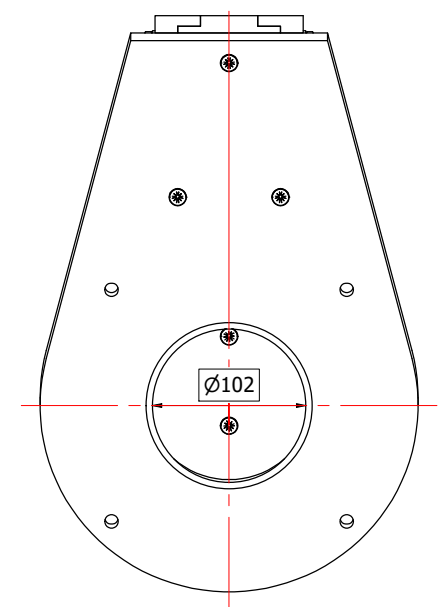

on-seating →

Linear dimensions tolerances acc. to: NEN-ISO 2768-c/ Laser cut dimensions tolerances acc. to ISO 9013-1

Please refer to our installation manual for more detailed information regarding wall mounting

Name: _____

Date: _____

Signed for agreement: _____

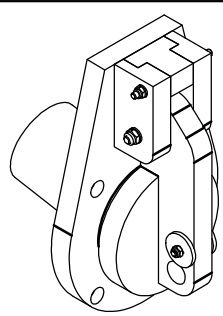

Opening ID: Ø102mm
 Material: HDPE, SS316, EPDM
 Max load from bottom invert level (B.I.L.)
 1.11 MWC long period (= 50 years)
 5.0 MWC short period (= 72 hours)
 Synthetic rubber (EPDM)
 Opening Angle (OA)
 Inner diameter (ID)
 Outer diameter (OD)
 All dimensions in mm

Mounting detail

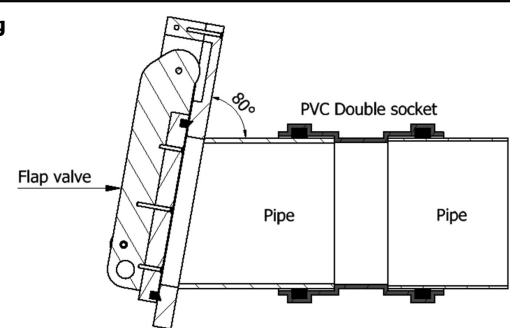

Postbus 288 3640 AG Mijdrecht
 T: +31 (0)297 - 26 29 29
 F: +31 (0)297 - 26 12 72
 E: info@aquafix.nl
 W: www.aquafix.nl

Flap valve ATKS Ø110 - HDPE/SS316L

Rev.: 1

Model: Spigot socket/coupling mount 10° (S)

17/7/2023

Articlenr.: 670ATK0100S

± 4 kg

Des.: DG

Date: 9/4/2020

Scale: 1 : 5

Size: A3

Dwg. nr.: ATKS1900171

Sheet: 1

Dimensions: The stated dimensions are approximate. Nominal sizes are given in mm. We advise you to measure the materials immediately after delivery before proceeding to installation. No rights may be derived from the measurements in this drawing. **Copyright:** This drawing remains the exclusive property of Aquafix Milieu BV. No part of this drawing may be copied, reproduced or made available without the express consent of Aquafix Milieu BV.

